

FLC-36 WASHER

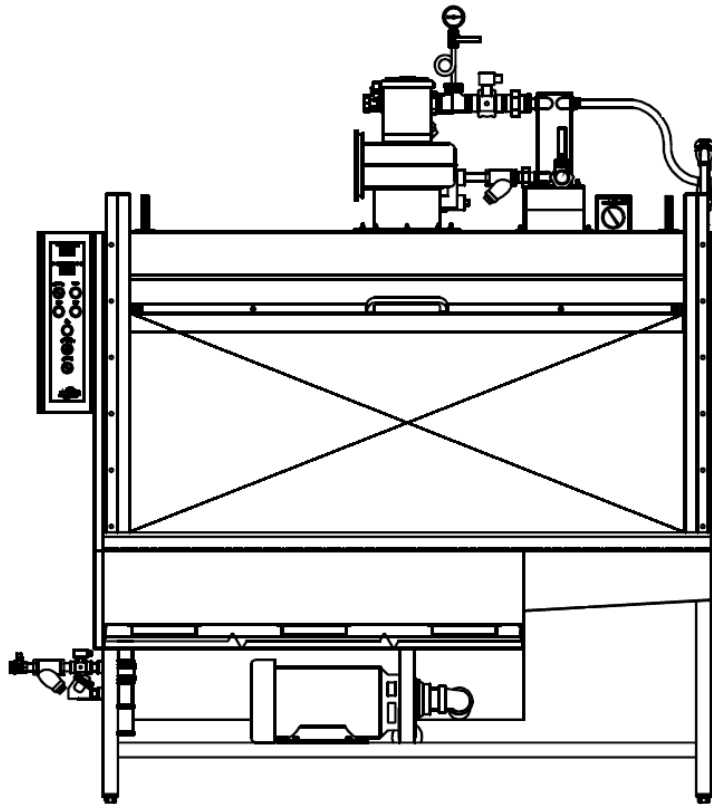

ALVEY



FLC-36 FRONT-LOAD WASHER
TABLE OF CONTENTS

This **ALVEY WASHING EQUIPMENT** machine was installed by

(lead installer)

on the day of

(month / day / year).

Serial #: _____

Customer PO #: _____

Manufacturer SO #: _____

For parts and services, call

ARMOR AFTERMARKET

at

1-800-725-9957

or email partsandservice@armoraftermarket.com



FLC-36 FRONT-LOAD WASHER

TABLE OF CONTENTS

Dear Valued Customer,

Thank you for your trust in, and relationship with Alvey Washing Equipment. We hope you have many years of uninterrupted service from our product.

If you need parts, service, or support, contact **ARMOR AFTERMARKET** at 1-800-725-9957, or email partsandservice@armoraftermarket.com. Some advantages of requesting **ARMOR AFTERMARKET** to fill your replacement parts orders are:

1. Being the original manufacturer of this equipment offers simplicity in order replacement.
2. We are entitled to original equipment manufacturer discounts, which are passed on to our customers.
3. It is our primary responsibility to serve you in a timely and professional manner.

A suggested spare parts list for your machine is included in the CD we are providing your company. This CD has been created to assist you in learning about and using your new machine. The program will help you quickly find documentation and instructions regarding common usage and parts. Adobe Acrobat Reader will be required to view the manual; a download is available from the CD.

If the CD does not start automatically, run "CD_Start.exe" on your CD drive. Should you have problems reading any files, please contact us.

Sincerely,

Alvey Washing Equipment

Documentation and Manual Team and The Parts and Service Department



FLC-36 FRONT-LOAD WASHER

TABLE OF CONTENTS

Section	Title	Page
I.	Warranty and Notice	1
II.	General Description	3
III.	Setup	5
IV.	Startup and Operation	7
V.	Maintenance Schedule	9
VI.	Troubleshooting Guide	11
VII.	Recommended Spare Parts	15



FLC-36 FRONT-LOAD WASHER

I. WARRANTY

ACCEPTANCE – The quote of which these terms and conditions are incorporated therein in their entirety is conditioned upon its written acceptance by the customer (hereinafter “Purchaser”) within thirty (30) days from the date of the quote, and prior to such written acceptance, the quote and these terms and conditions are subject to change without notice. Upon Manufacturer’s (as defined below) acceptance of the purchase order, these terms and conditions shall be binding on Purchaser. All previous agreements, understandings and quotations are superseded by these terms and conditions. No modification of any of these terms and conditions herein shall be binding on Manufacturer unless such modification is agreed to in writing by an authorized representative of Manufacturer from the Mason Office of Armor Metal Group. “Manufacturer” as used herein shall be deemed to mean the manufacturer as identified on the quote of which these terms and conditions are incorporated therein.

SHIPPING DATES - Shipping dates are approximate, based on prompt receipt by Manufacturer of all necessary information, and are subject to change by reason of factory conditions. Receipt of the product quoted (hereinafter the “Equipment”) by the Purchaser shall constitute a waiver of all claims for delay.

PRICING - All prices quoted by Manufacturer are subject to change at any time and to any addition which may be necessary to cover any regional or nationwide material price increase or shipping surcharge to Manufacturer for materials. Manufacturer reserves the right to correct all typographical or clerical errors, which may be present in Manufacturer’s prices or specifications.

TERMS - Unless otherwise mutually agreed upon in writing, the Equipment is sold F.O.B. Manufacturer’s Factory. Terms of this sale are subject to separate written agreement between Manufacturer and Purchaser, to be determined at the time of consummation of this sale. Unless otherwise provided in such separate written agreement, payment in full shall be due and invoiced when the Equipment is ready for delivery. No cash discounts are allowed unless otherwise specifically provided by Manufacturer in writing. If, in the exclusive judgment of Manufacturer,

the financial condition of Purchaser at any time does not justify the commencement or continuance of production or shipment on the terms specified herein, Manufacturer may, in addition to all other remedies it may have at law or in equity, make a written demand for full or partial payment in advance, suspend its performance until such payment is made and cancel the contract if such payment is not received by Manufacturer within 30 days after delivery in person or mailing of such demand by Manufacturer. If Purchaser fails to pay within ten (10) days after the due date thereof any sum required to be paid by Purchaser to Manufacturer hereunder, Purchaser will pay to Manufacturer for each delinquent payment or part thereof interest on such delinquent amount from the due date thereof until paid at the lesser of the maximum interest rate allowed by law or eighteen percent (18%) per annum. Sale price shall be payable in current funds of the United States at par.

BACKCHARGE POLICY - When a suspected problem develops in the field involving Manufacturer’s product, Manufacturer should be contacted immediately. Purchaser shall give a written statement to Manufacturer detailing the nature of the problem and its probable cause. Manufacturer will evaluate the issue, and if confirmed to be a warranty issue, will respond in accordance with the warranty provisions below. Unless otherwise agreed in writing by Manufacturer, Manufacturer’s personnel shall perform all required field service work. In the event an outside party performs any work for which the Manufacturer has not consented in writing, Purchaser shall be responsible for all such work. Prior consent consists of a written purchase order from the Manufacturer detailing the work to be performed and cost.

DUTY, TAXES, PERMITS AND BONDS - Any Federal, State, local or Import Duty or tax arising out of either sale, manufacture or installation of the Equipment or performance of the within contract, is not included in the quoted price, and where necessary, will be made an additional charge to be paid by Purchaser.



FLC-36 FRONT-LOAD WASHER

I. WARRANTY

All licenses and permits, including without limitation, any building or erection licenses and permits, if necessary, shall likewise be paid by Purchaser; and should Manufacturer be required to furnish any Bond or Bonds on the within contract, the cost thereof shall also be added to the quoted price.

ADDITIONAL MATERIAL AND LABOR - Any material added to, or labor performed on or in connection with the Equipment or installation thereof, shall be at Purchaser's own expense, unless otherwise agreed to in writing by Manufacturer.

SAFETY DEVICES - Manufacturer will supply such safety devices or fire protection equipment as is specified in writing in its proposals. If Purchaser desires or requests through local, State or Insurance Underwriter's Specifications or regulations, other additional safety devices or equipment, Manufacturer will undertake, without being obligated therefore, to furnish same at Purchaser's cost. Manufacturer assumes no liability for loss or damage to persons or property occasioned by any accident or casualty resulting from the use of fuel gas, fuel oil, oven or immersion tube atmosphere gas in connection with the Equipment.

USE OF SPECIFICATIONS AND DRAWINGS - The drawings, designs, specifications and data accompanying any proposal are Manufacturer's property and are subject to recall by Manufacturer at any time. Such drawings, designs, specifications and data, or any part of them, shall not be used by Purchaser for competitive bidding or similar purposes without Manufacturer's prior written approval.

TITLE AND OWNERSHIP - It is the intention that the Equipment be sold to Purchaser and that title to the same shall be acquired by Purchaser upon shipment from Manufacturer's premises. Manufacturer shall retain a purchase money security interest lien on each piece of Equipment, including without limitation, any accessories to such Equipment, proceeds from the sale thereof and any insurance proceeds related to such Equipment, until final payment thereof is made as per the agreed terms. If Manufacturer gives Purchaser possession before final payment is made, it is hereby mutually agreed that:

a) The title and the right of possession of the Equipment shall transfer to the Purchaser upon shipment; provided however, Manufacturer shall retain a purchase money security interest lien on each piece of Equipment, including without limitation, any accessories to such Equipment, proceeds from the sale thereof and any insurance proceeds related to such Equipment until full and final payment therefore (including payment of any promissory notes and/or other security taken in lieu of or in accordance with the terms hereof) shall have been made. Purchaser also authorizes Manufacturer to act as its agent and attorney-in-fact (where permitted by law) for the limited purpose of preparing, executing in Purchaser's name, and filing on its behalf, a financing statement (for example, a UCC-1) to perfect Manufacturer's purchase money security interest in each piece of Equipment. Until title or license has passed to Purchaser and full and final payment has been received by Manufacturer, Purchaser shall not cause nor permit any piece of the Equipment to be sold, leased, or subject to a lien or other encumbrance other than Manufacturer's security interest;

b) In the event of default or breach of any of the Terms and Conditions of the contract, Manufacturer may, at its option, repossess the Equipment and all additions thereto, wherever found, free from all claims whatsoever;

c) Any risk of loss during shipment shall be borne by Purchaser and any loss or damage to the Equipment during shipment shall not relieve Purchaser of its obligations hereunder, including but not limited to making full and final payment to Manufacturer.

The Equipment, or any part thereof, shall not be considered a fixture or be incorporated into realty by reason of its attachment thereto, and may be separated from realty, as well as personality, for the purpose of repossession. Manufacturer shall not be liable to Purchaser, nor shall Manufacturer be subject to any legal proceedings, criminal or civil, for Manufacturer's acts in such repossession, nor for the repayment of any money paid before such repossession as part payment for the Equipment, which shall be retained by Manufacturer as or on account of liquidating damages.



FLC-36 FRONT-LOAD WASHER

I. WARRANTY

In addition to the purchase money security interest lien described above, Manufacturer shall have the right to elect or assert Manufacturer's claim of a mechanics lien against the property upon which the Equipment may be erected and to waive Manufacturer's right to repossess under section (b) above at any time before the expiration of the time fixed by law for filing such lien.

CLAIMS/LIABILITY -

a) Manufacturer shall not be liable for loss, damage, detention, or delay resulting from causes beyond its control or by acts of God, including floods, and acts of foreign nations, or caused by fire, strike, civil or military authority insurrection or riot, embargoes, car shortages, wrecks or delay in transportation.

b) Manufacturer shall have no responsibility for loss or damage to the Equipment after delivery to the carrier.

c) Manufacturer's liability arising out of the supplying of the Equipment or its use shall not under any circumstances exceed a credit of the purchase price, F.O.B. Manufacturer's factory, of the Equipment.

d) IN NO EVENT SHALL MANUFACTURER BE LIABLE FOR LIQUIDATED DAMAGES, OR INDIRECT, OR CONSEQUENTIAL DAMAGE OF ANY NATURE.

WARRANTIES -

a) Manufacturer warrants to Purchaser that the material and workmanship of the Equipment is of good quality and free of defects and the Equipment of its own manufacture and design delivered hereunder shall be of the kind and quality described in the specifications, and that it shall be suitable for performing the work therein described; provided, however, that the work for which it is intended shall have been fully and adequately presented, shown and described to Manufacturer. The warranty period will start upon shipment from a facility of Manufacturer and conclude based upon a separate prearranged warranty period agreed to in writing by Manufacturer.

b) EXCEPT AS SPECIFICALLY PROVIDED IN (a) ABOVE, MANUFACTURER MAKES NO WARRANTY, EXPRESS OR IMPLIED, RELATING TO THE

EQUIPMENT, ITS MERCHANTABILITY OR FITNESS FOR ANY PARTICULAR PURPOSE.

c) Manufacturer does not provide a separate warranty for parts or components not manufactured by Manufacturer. Equipment, parts and accessories made by other manufacturers are warranted only to the extent of the original manufacturer's warranty to Manufacturer, which if extendable, Manufacturer will extend to Purchaser.

d) In the event of Manufacturer's breach of its warranty as provided in (a) above, Manufacturer's total liability shall be to repair or replace the Equipment and in no event shall Manufacturer have any liability for any consequential, incidental or other special damages, including but not limited to damages or loss of profits resulting from failure of the Equipment or delay caused by its repair.

e) All transportation costs of returning defective goods shall be borne by Purchaser. All transportation costs of returning repaired or replaced products to Purchaser shall be borne by Purchaser.

f) This warranty shall not be in force and effect unless: Purchaser is current with all payments due to Manufacturer; Purchaser gives Manufacturer immediate notice of defective part or parts; Purchaser affords the Manufacturer the opportunity to inspect defective part or parts; material is still property of the original owner; material is still part of the original installation operating under normal usage (eight hours per day and five days per week constitutes normal usage); and material is properly maintained and lubricated per factory instructions.

g) THE ABOVE WARRANTY DOES NOT COVER PARTS WHICH UPON INSPECTION ARE DETERMINED BY MANUFACTURER TO HAVE BEEN SUBJECTED TO MISUSE, NEGLIGENCE, ALTERATIONS, ACCIDENT, ABUSE, DAMAGE BY FIRE, FLOOD OR OTHER SIMILAR CASUALTY.

PATENTS - Manufacturer shall hold Purchaser harmless from any and all costs and damages which shall be recovered against Purchaser in any suit at law or in equity for any infringement of any Letters Patent by reason of the use by Purchaser of the Equipment



FLC-36 FRONT-LOAD WASHER

I. WARRANTY

herein specified; provided and upon the express condition that the Equipment is used in the manner directed and exclusively for the purpose for which it is sold without any changes and installed or used in compliance with Manufacturer's plans and instructions, and upon further express condition that Purchaser shall immediately after service of the writ in any such suit at law or in equity notify Manufacturer in writing of the commencement of such suit, giving the names of the parties and the title of the court, and shall permit Manufacturer to defend same by its own counsel and at its own expense and to have exclusive control and management of the defense, and that Purchaser shall give Manufacturer all needed information, assistance and authority to enable Manufacturer to defend such suit.

INDEMNIFICATION - Purchaser agrees to indemnify Manufacturer, and hold Manufacturer harmless from, all costs and expenses incurred by Manufacturer, including, without limitation, costs of investigation, attorneys' fees, and amounts paid in settlement or satisfaction of claims, proceedings, or judgments, in connection with all claims and proceedings against Manufacturer based upon claimed defects in design in any item or items manufactured for Purchaser by Manufacturer to Purchaser's design and/or specifications.

CANCELLATIONS - In the event Purchaser should request cancellation of this contract, or part of it, Purchaser agrees to pay Manufacturer the contract price on any articles which are delivered and ready for delivery on the date when such cancellation becomes effective. As to all such articles not so delivered, Purchaser shall have the option:

- 1) To require completion and to pay the contract price thereof; or
- 2) To reimburse Manufacturer for actual expenditures made with respect to the articles which are uncompleted; to reimburse Manufacturer for commitments incurred with respect to the uncompleted articles of the contract; and to pay Manufacturer for the anticipated profit of the entire contract.

Manufacturer may, by written notice to Purchaser and without any liability, cancel Purchaser's contract if

Purchaser (i) fails to perform any of the terms and conditions hereof and does not cure such failure within a period of 10 days after receipt of written notice from Manufacturer specifying such failure: (ii) in Manufacturer's opinion has not established or maintained credit to meet promptly the payment terms imposed by Manufacturer: (iii) becomes insolvent, makes an assignment in favor of creditors, or becomes subject to any bankruptcy, dissolution, or similar proceedings; or (iv) is merged into, or all or a substantial part of its assets are sold to, another company.

FORCE MAJEURE - Delays by Manufacturer or by Purchaser in the performance of this contract shall be excused whenever Manufacturer or the supplying manufacturer is prevented from producing or delivering, or Purchaser from receiving or using the above material, by strikes, differences with workmen, fires, accidents, delays or difficulties in transportation acts of God or the public enemy, or other causes beyond the reasonable control of Purchaser or of Manufacturer or of the supplying manufacturer, as well as acts or demands of the government in times of war or national emergency. Any such delayed performance, however, shall not in any way invalidate this contract or any part thereof.

JURISDICTION - Purchaser irrevocably consents and voluntarily submits to personal jurisdiction of the courts located in Warren County and the United States District Court for the Southern District of Ohio, Western Division in any proceeding arising out of or relating to the contract and agrees that all claims raised in such proceeding may be heard and determined in such court.

GOVERNING LAW - The contract shall be governed by and construed in accordance with the internal laws of the State of Ohio, United States of America, without regard for its choice and or conflict of laws provisions and without regard to the United Nations Convention on Contracts for the International Sale of Goods.

Purchase Orders and/or contracts may only be accepted in writing by an authorized representative of Manufacturer from the Mason Office of Armor Metal Group.

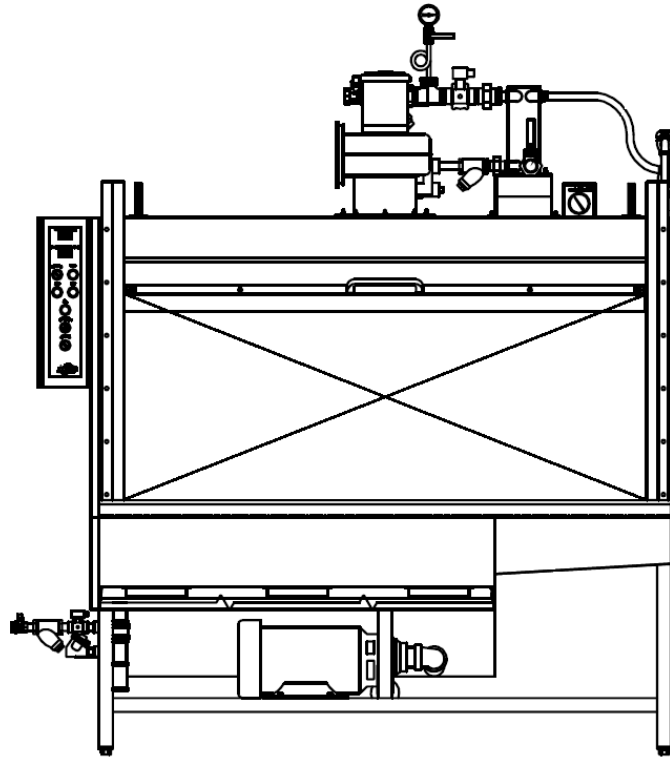

OVERVIEW

The Alvey Model FLC-36 is a compact, completely automatic, stainless steel, front load washer designed to subject the work to a recirculated hot detergent wash and fresh water sanitizing rinse. There are three rack-loading positions within the washer.

This model is designed to accommodate roll around carts, pots, pans, utensils, trays, and other dishware.

SPECIFICATIONS:

- Wash Chamber: 74" wide, 30" deep, 27" high
- Weight (shipping): 1,250 lbs (567 kg)
- Capacity: up to 36 sheet pans or 140 quart mixing bowls
- Constructed of all-welded 14 gauge type 304 stainless steel with polished finish.
- Steam coil tank heating
- Rotating spray arms with stainless steel nozzles
- UL listed stainless steel control panel
- 15 HP enclosed fan-cooled horizontal pump
- 50 gallon (189 liter) tank capacity
- Vertical opening stainless-steel door
- Door operated safety shut-off switch
- Electronic digital temperature-control
- Pump pressure gauge
- Automatic water fill
- Adjustable sanitary feet



FLC-36 FRONT-LOAD WASHER

TABLE OF CONTENTS

Selecting a Location

When selecting the location to install your Alvey FLC-36 front-load washer, review the dimension sheets and consider access to the utility requirements.

- Determine the minimum distance from outside wall or roof to optimize ventilation.
- Ensure there is ample floor space for maintenance and for storage of cleaned and soiled work.
- Consider access to all necessary utility requirements, including water, electricity, and steam or gas, if applicable.

Ensure sufficient access for inspection and maintenance.

Receiving the Machine

The machine is provided in one main section. Accessory items are located inside, and the door is wired shut.

Remove the wire from the door and remove the shipping blocks from under counterweights in the back of the machine.

Inside the washer, you may find the optional work tray, exterior rinse piping assembly and any accessory equipment that has been purchased, such as exhaust fan, booster, baskets and racks. The items will be banded together. Accessory items and rinse piping should be unbound and removed from the machine. Some items may be crated separately.

Installation tips, maintenance and operating manual is located inside control enclosure. Before start-up, place green solenoid coil back onto the exterior rinse valve body located on top of washer to prevent damage.

Receiving the Machine

After machine has been removed from the shipping crate, spot in the desired location. At this time, make sure machine has enough clearance all the way around for future maintenance and removal of components. Machine can also be leveled at this time by adjustment of the legs. Make sure there is weight on all four (4) legs after adjustment.

Service Connections

Refer to dimension sheets in the back of this manual for location of each service connection. Ensure that all service connections are properly hooked up.

Ventilation

A 7 ⁹/₁₆" diameter watertight duct or exhaust fan (if purchased) is required for the Model FLC-36. Be sure to use proper inside lapping of joints and to use the **provided gasket** between the fan and washer housing so that condensate is not permitted to seep out at the connections.

Electrical Wiring

The machine has already been internally wired; all that is required is to make a connection to the outside power lines.



Note: If the fan has been removed for shipping, connect it to the main control panel.



Caution: Armor highly recommends the placement of a fused safety switch in the electric line in order to permit maintenance of the machine without danger of shock or electrocution.



Note: The outside power line should be connected to L-1, L-2, and L3 on the terminal block. See the Wiring Diagram provided with this manual.

Water Connection

If the machine comes equipped with a steam booster, a 1 1/4" single-point water connection is provided.

If the machine comes equipped with an electric or gas tank heater, the machine comes equipped with a 3/4" diameter single point water connection, located at the top of the washer on the steam booster water inlet.



FLC-36 FRONT-LOAD WASHER

III. SETUP

Daily Start-Up

1. Turn on power at customer-provided Disconnect Switch. Electric or gas booster will be connected to a disconnect separate from washer
2. Turn on washer's Main Power Switch. The white "Power On" indicator will light.
3. Ensure that the drain valve is in the closed position.
4. Close door to begin automatically filling the tank. The unit will stop filling the tank when the proper level is reached.
5. Turn on the Wash Heat Switch to activate the steam heat coil in the wash tank.

Sequence of Operation

1. Set the wash temperature controller, located on the front of the main control panel, to 160°F / 71.1°C (See temperature controller manual for setting instructions).
2. When the temperature for the wash tank reaches the 160°F/71.1°C set point, the washer door can be opened and the racks can be loaded.
3. Adjust the Cycle Time Switch to the light, medium or heavy soil position depending soil conditions.
4. Push the green Cycle Start Button to begin wash cycle. The red In Cycle Indicator will light, and stay lit until the cycle is complete.
5. Unload washer after In Cycle indicator goes off and wash cycle ends.

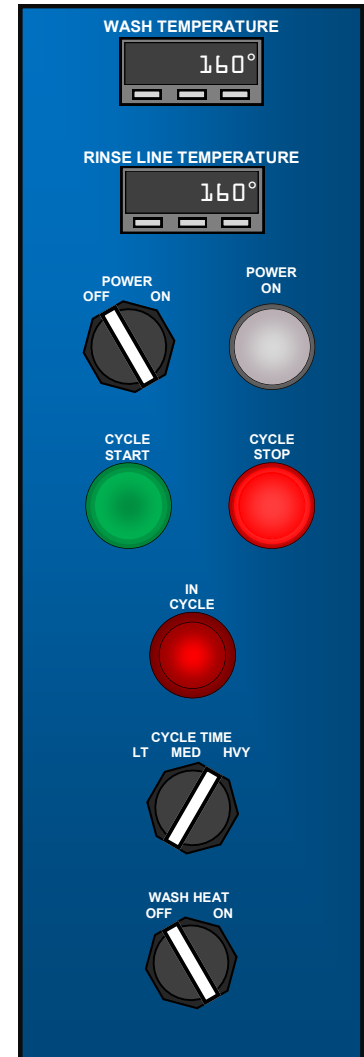

 **Note:** When washer is connected to central exhaust system, means must be provided to prevent the exhaust of moist air during the operation of the washer.

Detergent

When the solution reaches operating temperature, add the proper amount of cleaning compound at the rate recommended by your chemical supplier. If the detergent is in a powder form, pour the powder in the filter baskets, then close the door and run the pump until all compounds have been dissolved. If the compound has been broken up or partially dissolved, this operation will go faster.

 **Notes:** Use of an automatic detergent dispenser is recommended. To insure economical use of the compounds, be sure that the sensing probes are kept clean of any foreign matter. Consult your cleaning compound supplier for recommendations. To obtain satisfactory cleaning, we cannot stress enough the importance of the proper detergent. The temperature controller is located in the control panel.

 **Caution:** The cleaning compound should be the non-foaming type and should not contain a chemical substance that will damage copper or aluminum.



FLC-36 FRONT-LOAD WASHER

TABLE OF CONTENTS

End of Day Maintenance

1. Open the drain valve to remove water from tank.
2. Turn off power to the washer.
3. Remove all filter screens and clean thoroughly.
4. Flush housing and tank thoroughly.
5. Inspect interior of machine for:
 - Nozzle clogging - clean if necessary.
 - Spinning arms freedom of movement – remove and clean if necessary.
6. Remove any debris from the heating surfaces, temperature and level probes.
7. Replace all filter screens and leave door open so that interior will air dry.
8. Wipe down exterior of machine.

Weekly Maintenance

Remove end caps located at the end of each wash spray pipes. Inspect wash nozzles for clogging. If clogged, use a small diameter wire such as a paper clip, to force any nozzle obstructions back into the pipes. When nozzles are removed, take care to adjust them to their original position when replacing. With end caps removed, close the door and start the pump. All debris will be blown out of the ends of the pipes.



Caution: Run pump for only ten seconds. Pump damage will occur if the pump is allowed to run for longer than ten seconds.



Notes: There is a small hole drilled in the side of one of the spinning spray pipes. Be sure this hole is kept clear of clogging. If this hole becomes clogged, the spray arms shall not spin properly.

FLC-36 FRONT-LOAD WASHER
V. MAINTENANCE SCHEDULE

After running, open door and replace the end caps. Remove the spinning arm assemblies and flush the bearings with clean water until free movement is achieved.

The FLC-36 Pan Washer is equipped with a pump utilizing seals. The pump discharge pressure will read approximately (40-50 PSI). To help prevent further pump damage, periodically check the pump casing for any foreign matter. Grease pump motor every six months. Check direction of rotation after installation or any electrical maintenance.

The exhaust fan removes vapors from cabinet during the end of the completed cycle. The fan is equipped with sealed bearings, which will not need grease.

Lubrication Guide

Pump Motor: Grease twice yearly.

Exhaust Fan and Motor: No greasing required.



FLC-36 FRONT-LOAD WASHER

TABLE OF CONTENTS



FLC-36 FRONT-LOAD WASHER

TABLE OF CONTENTS

FLC-36 FRONT-LOAD WASHER

VI. TROUBLESHOOTING GUIDE

Wash Pump

PROBLEM	DIAGNOSIS	SOLUTION
Low Pressure	Pump is running backwards.	Check main electrical wire phasing.
	Nozzles missing.	Replace missing nozzles.
	Leak in discharge piping.	Tighten all pipe fittings.
	Faulty pressure gauge.	Replace gauge.
	Excessive soap suds.	Contact chemical supplier.
	End caps loose or missing.	Tighten or replace end-caps.
High Pressure	Clogged nozzles or discharge piping.	Find and remove clogged nozzle; dislodge and
	Discharge piping clogged.	Remove obstructions.
	Faulty pressure gauge.	Replace gauge.
Pump Vibration	Worn impeller.	Remove impeller from pump, examine and replace if necessary. (See Pump Instruction
	Worn wear ring.	Remove wear ring from pump, examine and replace if necessary.
	Bent shaft.	Remove shaft from pump, examine and replace if necessary.
	Clogged impeller.	Remove obstruction.
	Worn motor bearings.	Replace bearings.
Motor Overheating	Low voltage.	
	Missing spray nozzles.	Replace missing nozzles.
	Faulty motor.	
	Motor running backwards.	Check main electrical wire phasing and connections.
Motor Will Not Start	Tripped breaker in high voltage (3 phase).	Check fuses in customer-provided disconnect.
	Tripped breaker on transformer secondary.	Reset circuit breaker
	Overload has dropped out.	Reset overload.
	Faulty door switch—door not fully closed.	
	Faulty coil in pump starter.	
	Faulty switch.	

FLC-36 FRONT-LOAD WASHER
VI. TROUBLESHOOTING GUIDE

Fresh Water Rinse

PROBLEM	DIAGNOSIS	SOLUTION
Will Not Shut Off	Dirty rinse solenoid (piston sticking open).	Clean solenoid valve body.
Will Not Turn on	Dirty rinse solenoid (piston sticking closed).	Clean solenoid valve body.
	Faulty solenoid valve coil.	Replace coil.

Exhaust Fan

PROBLEM	DIAGNOSIS	SOLUTION
Exhaust Fan Vibration	Worn bearings.	Replace bearings.
	Wheel out of balance.	
	Bent shaft.	Replace shaft.
Exhaust Fan Motor Overheating	Low voltage.	
	Bent shaft.	Replace shaft.
	Worn bearings.	Replace bearings.
	Motor running backwards.	Check main electrical wire phasing and connections.

Steam Injector

PROBLEM	DIAGNOSIS	SOLUTION
Will Not Heat.	Temperature controller set too low.	Increase temperature on controller.
	Faulty temperature controller.	Replace controller.
	Clogged steam coil.	Remove, clean out, and replace.
	Clogged steam strainer.	Remove, clean out, and replace.

Steam Booster

The primary function of the steam booster is to raise water temperatures to 180 degrees to meet sanitation requirements for rinsing. When installing the booster, it will require the following services:

1. Steam Maximum 10 PSI flow rate. Higher pressure will result in unsatisfactory results.
2. Water Design flow pressure is 20 PSI 120-140 degree F. incoming water temperature measured at the pressure gauge at the freshwater rinse manifold.
3. Condensate return required.
4. Electric connects for solenoid if booster is not factory mounted.

Note: This booster has been designed to operate on specific pressures, temperatures and volumes. If the correct information has not been supplied, the booster will not perform properly. If you have supplied the incorrect information, Alvey will advise on the problem, but will not share any cost.



FLC-36 FRONT-LOAD WASHER TABLE OF CONTENTS

FLC-36 FRONT-LOAD WASHER VI. TROUBLESHOOTING GUIDE

Spinning Assembly Arms

PROBLEM	DIAGNOSIS	DIAGNOSIS
Arms Will Not Turn	Remove arms and flush out.	Check to ensure arms spin freely before reinstallation.
	Drive hole clogged.	Remove debris from drive hole.
	Ball bearings are worn.	Replace worn ball bearings.
	Ball bearings clogged.	Remove debris from bearings.



FLC-36 FRONT-LOAD WASHER

TABLE OF CONTENTS



FLC-36 FRONT-LOAD WASHER TABLE OF CONTENTS

FLC-36 FRONT-LOAD WASHER VII. RECOMMENDED SPARE PARTS

Recommended Spare Parts

Description	Part Number	Quantity
Door Cable	44544	2
3/4" Rinse Valve	44707	1
Wash Nozzles	11235	6
Rinse Nozzles	43509	6
Hub Assembly Kit—Lower/Upper Arms	44483	2
Wash Arm End Plug	43522	2
Pressure Gauge (Freshwater Rinse Manifold)	42540	1
Pressure Gauge (Wash Pump)	42767	1



ALVEY



ISO 9001
Quality

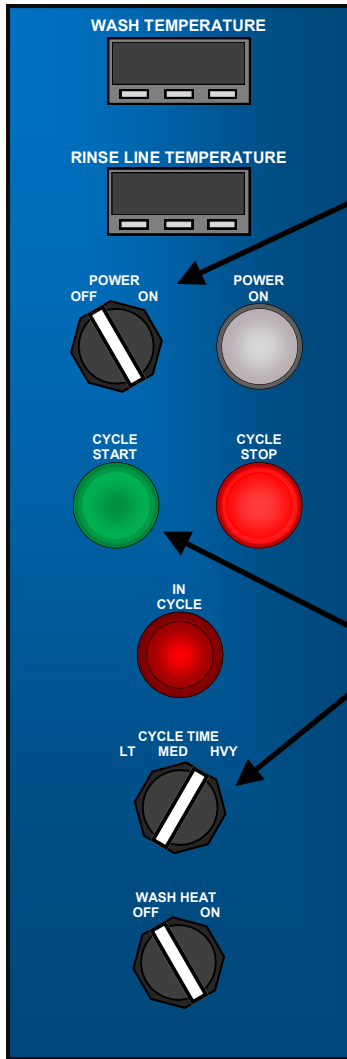

1. Turn on power.

2. Fill tank.

- A. Open manual valve.
- B. Allow water to rise to overflow level.
- C. Close door.

3. Load Machine.

4. Close door.

5. Select Wash Time.

6. Press 'CYCLE START' button.

1. Encienda la alimentación.

2. Llene el tanque.

- a. Abra la válvula manual.
- b. Levante el agua para alcanzar el nivel de desbordamiento.
- c. Cierre la puerta.

3. Coloque los platos sucios en la máquina.

4. Cierre la puerta.

5. Seleccione el tiempo de lavado.

6. Presione el boton "Cycle Start".