



ALVEY

FLC-36 Front Load Washer

No commercial kitchen facility is complete without an Alvey® Equipment washer

The Alvey® Model FLC-36 washer is designed for front-loading convenience with a large capacity to accommodate standard delivery carts and up to 36 sheet pans. This efficient stainless steel model is ideal as a high-volume pot, pan, bucket, and utensil washer. The FLC-36 features a heavy duty work grate tray allowing larger items to be placed directly in the washer.



Features

Wash Chamber Housing

- 74" wide by 36" deep by 28" high
- Holds up to 36 sheet pans
- Holds up to a 140 quart mixing bowls
- Four revolving stainless steel spray arms with stainless steel nozzles located above and below wash tray
- Adjustable nozzles located on bottom of wash chamber for hard to reach places
- Stationary rinse nozzles located above and below wash tray
- Rinse water used to replenish wash medium

Wash Pump

- 15 HP totally enclosed, fan cooled motor, horizontally mounted pump delivering 240 GPM at 55 PSI
- The wash spray arms are provided with easily removable nozzles and end caps for maintenance and cleaning
- Removable stainless steel front cover panel for easy maintenance and cleaning
- Rotating spray arm assemblies located above and below wash area
- Stainless steel wash and rinse pipes

Tank and Housing

- Constructed of 12 gauge type 304 polished stainless steel
- 50 gallon capacity
- Stainless steel filter screens
- Drain valve with overflow

Door

- Vertical opening/stainless steel
- Counter weighted for easy operation
- Door operated safety switch

Control Panel

- UL listed stainless steel panel
- Programmable cycles for light, medium, and heavy
- Electronic temperature control
- Digital temperature gauges

Additional Features

- NSF Certified
- Wash and rinse pressure gauges
- Rinse line strainer
- Adjustable sanitary feet
- Wash grate tray
- Automatic hold-down for light items



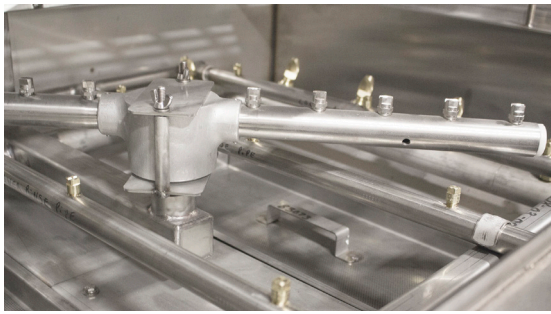

FLC-36 Front Load Washer

Detailed Dimensions

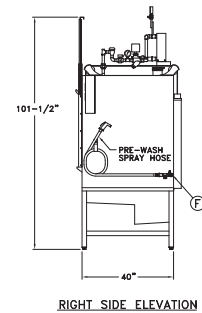
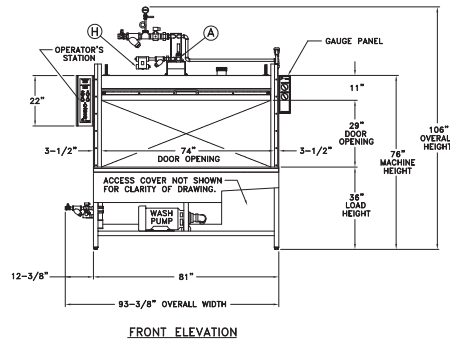
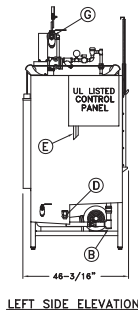
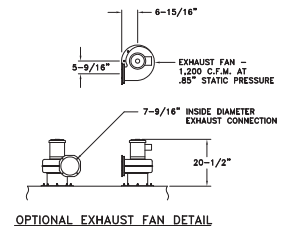
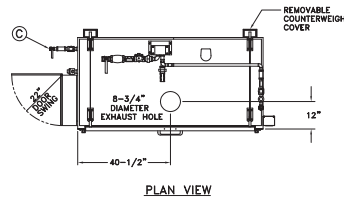

Accessories and optional equipment

- Insulated housing
- Wash down hose and nozzle
- Steam pressure regulator
- High capacity exhaust fan
- Hands-free automatic hold down
- Prison package
- Warm rinse heat booster for gas, electric or steam

Heating Options

- Stainless steel steam heated coils
- Electric immersion heaters
- Gas burner (natural or propane)

Voltage Options

- 208V
 - 220/240V
 - 460/480V
- International options available

Optional baskets for Alvey® Model FLC-36

Model #	Description	Products
R01078	Sheet pan/bun pan rack - (12) pockets	18" x 26" x 1" sheet pans
R01035	Steam table insert rack - (4) pockets	Full size 4" deep inserts
R01042	Cake pan/piepan rack - (5) pockets	Pans 2-1/2" deep
B18311	Utensil basket with lid. 23" x 23" x 6"	Kitchen utensils
B18320	Miscellaneous pan basket. 23" x 23" x 10"	Pans 10" deep



Contact us today
 4600 N. Mason-Montgomery Road | Mason, OH 45040
 513-923-5601 | Sales@AlveyWashing.com
www.AlveyWashing.com

